

ZTE-J G500
GoTa Digital Trunking Phone
User Manual

Copyright © 2011 ZTE Corporation

All rights reserved.

No part of this publication may be excerpted, reproduced, translated or utilized in any form or by any means, electronic or mechanical, including photocopying and microfilm, without the prior written permission of ZTE Corporation.

The manual is published by ZTE Corporation. We reserve the right to make modifications on print errors or update specifications without prior notice. The information on the package is only for your reference. Images are for your reference only. Please check the product model before purchasing.

Version No.: R1.0

Manual No.: 079584503457

Edition Time: 20110725

Contents

Safety Information	6
General Care	6
General Guidelines	6
Road Safety	7
Hospital Safety	7
Emergency Service	7
Third Party Equipment	7
Vehicles Equipped with an Airbag	8
Aircraft Safety	8
Radio Frequency (RF) Energy	8
FCC Compliance	9
Disposing of Your Phone	10
Limitation of Liability	10
Your Phone	11
Phone Overview	11
Keys and Functions	12
Getting Started	15
Installing Battery and (U)SIM Card	15
Inserting Memory Card	17
Charging Your Phone	19
Security Settings	21
Handset Code	21
PIN Code	21
PUK Code	22
Restoring Factory Settings	22
Clear User Data	23
Basic	24
Switching On/Off	24
Indicators and Icons	24
Keypad Lock	25
Making a Normal Voice Call	25
Functions during Normal Voice Call	26
PTT Calls	27
Make PTT Calls	27
Receive PTT Calls	27

End / Exit PTT Calls	28
Functions during PTT Calls	28
PTT Watching Function	28
Set PTT Watching Function.....	28
Set PTT Watching List.....	28
Broadcast Call	29
Operation Method	29
PTT Emergency Calls	29
Text Input	30
Contacts	31
Adding Contact.....	31
PTT System Group.....	31
Searching Contact.....	31
Adding group	32
Setting Speed Dial.....	32
Viewing Speed Dial	32
Making a Speed Dial	32
Other Options	32
Message	34
Sending SMS	34
Message Settings.....	34
Call History	35
Multimedia	36
Music Player.....	36
Setting Music Play Mode.....	36
Managing Play List.....	36
Playing a Music	36
Voice Recorder.....	37
Recording.....	37
Playing a sound file	37
EBook.....	38
File Manager	39
Other Facilities	40
Alarm	40
Calendar	40
Reader.....	41

Stopwatch	41
Calculator.....	41
Unit Converter.....	41
Notepad	42
JAVA	42
Settings	43
Profile.....	43
Display Settings	43
Phone Settings	43
Call Settings.....	44
Connect Settings	45
Time and Date Settings	45
PTT Settings	46
GPS.....	48
Troubleshooting and FAQs	49
Technical Parameters	52
Declaration of RoHS Compliance.....	53
Disposal of Your Old Appliance.....	54
EC DECLARATION OF CONFORMITY	55

Safety Information

General Care

- If you want to clean your phone, please use clean fabric that is a bit wet or anti-static. Do not use harsh chemical cleaning solvents or strong detergents to clean it. Turn off your phone before you clean it.
- As your mobile phone can produce electromagnetic field, do not place it near magnetic items such as computer disks.
- Using the phone near electrical appliances such as TV, telephone, radio and personal computer can cause interference, which affects the function of the phone.
- Do not expose your mobile phone to direct sunlight or store it in hot areas. High temperatures can shorten the life of electronic devices.
- Prevent liquid from leaking into your phone.
- Do not drop, knock or harshly treat your phone. Rough handling can break internal circuit boards.
- Do not charge the mobile phone without battery.
- Do not short-circuit the battery, as this can cause excessive heat and fire.
- Do not store battery in hot areas or dispose of it in a fire to avoid explosion.
- Store the phone out of the reach of little children. The phone may cause injury if used as a toy.
- Be aware of the usage limitation when using a mobile phone at places such as oil warehouses or chemical factories, where there are explosive gases or explosive products being processed, because even if your phone is in standby mode, it still transmits radio frequency (RF) energy. Therefore, power off your phone if required.

General Guidelines

- If your mobile phone is lost or stolen, please report to your service provider or agencies of banning the use of your lost phone, which will

protect you from economic losses resulted from unauthorized use. You need to provide the phone's ESN/MEID number labeled. You can see ESN/MEID number after removing the battery. Please keep ESN/MEID number for future use.

- To protect your mobile phone from illegal use, please take the security measures as follows:
 - ▶ Set PIN code of the UIM card.
 - ▶ Take it with you as you can.

Road Safety

Pay attention to traffic safety. Do not use your mobile phone while driving. Park before making or answering a call.

Hospital Safety

- Some electronic devices are susceptible to electromagnetic interference sent by mobile phone if inadequately shielded, such as electronic system of vehicles. Please consult the manufacturer of the device before using the phone if necessary.
- Operating of mobile phone may interfere with medical devices like hearing aid and pacemaker. Please always keep the mobile phone more than 20 centimeters away from such medical devices when the phone is powered on. Do not carry the mobile phone in the breast pocket. Power the mobile phone off if necessary. Consult a physician or the manufacturer of the medical device before using the phone.

Emergency Service

On occasion of emergent calling, keep your phone in status of power on and in area of service. On the condition of standby, press the key to enter emergency phone number, and then press **Call key** to make a phone call.

Third Party Equipment

- Please use original accessories or accessories that are authorized by

the manufacturer. Using any unauthorized accessories may affect your mobile phone's performance, and violate related national regulations about telecom terminals, or even endanger your body.

- Do not connect the phone with other unauthorized peripheral equipments.
- Do not attempt to disassemble the mobile phone and battery by yourself. Non-expert handling of the devices may damage them.

Vehicles Equipped with an Airbag

- Before making or answering a call, you should pay attention to the local laws about using wireless mobile phones and take them into account in practical use.
- Safety airbag, brake, speed control system and oil eject system shouldn't be affected by wireless transmitting. If you do meet problems above, please contact your automobile provider.
- Please power off your mobile phone when refueling your automobile, and so do the place where duplex wireless equipments are banned. Don't put your phone together with flammable or explosive items, as inner spark may cause fire.

Aircraft Safety

- Follow the restrictions in aircraft. Wireless devices can cause interference in aircraft.
- Please power off your mobile phone before taking on till landing. In order to protect airplane's communication system from interference, it is never allowed to use mobile phone when it is in flight. Using mobile phone before the plane taking off should get aircrew's permission according to safety regulations.

Radio Frequency (RF) Energy

The exposure guidelines for mobile devices employ a unit of measurement known as the Specific Absorption Rate (SAR). The SAR limit stated in the international guidelines is 2.0 watts/kilogram (W/kg)

averaged over ten grams of tissue. Tests for SAR are conducted using standard operating positions with the device transmitting at its highest certified power level in all tested frequency bands. The actual SAR level of an operating device can be well below the maximum value because the device is designed to use only the power required to reach the network. That amount changes depending on a number of factors such as how close you are to a network base station.

The highest SAR value when tested according to international testing procedures recommended by International Guidelines for Exposure to Radio Waves (**ICNIRP**) for use is 0.71 W/kg.

SAR values may vary depending on national reporting and testing requirements and the network band. Use of device accessories and enhancements may result in different SAR values.

Notes:

The SAR limit of 2W/kg averaged over ten grams of tissue is the permitted level of RF energy for the general population. The standards and guidelines include a substantial safety margin designed to assure the safety of the public, regardless of age and health and to account for any variations in measurements.

FCC Compliance

- This device complies with part 15 of the FCC rules. Operation is subject to the condition that this device does not cause harmful interference.
- This device has been tested and found to comply with the limits for a Class B digital device, pursuant to Part 15 of the FCC Rules. These limits are designed to provide reasonable protection against harmful interference in a residential installation. This equipment generates uses and can radiate radio frequency energy and, if not installed and used in accordance with the instructions, may cause harmful interference to radio communications. However, there is no guarantee that interference will not occur in a particular installation. If this equipment does cause harmful interference to radio or television reception, which can be determined by turning the equipment off and on, the user is encouraged to try to correct the interference by one or

more of the following measures:

- Reorient or relocate the receiving antenna.
- Increase the separation between the equipment and receiver.
- Connect the equipment into an outlet on a circuit different from that to which the receiver is connected.
- Consult the dealer or an experienced radio/TV technician for help.
- Changes or modifications not expressly approved by the party responsible for compliance could void the user's authority to operate the equipment.
- The antenna(s) used for this transmitter must not be co-located or operating in conjunction with any other antenna or transmitter.

Disposing of Your Phone

- Never use any charger or battery damaged or worn out.
- Return the wear-out battery to the provider or put it in the appointed recycle place. Do not put it in familial rubbish.

Notes:

If the battery is broken, keep away from content. If it taints your skin, wash your skin with abundant fresh water and ask doctor help if necessary.

Limitation of Liability

ZTE shall not be liable for any loss of profits or indirect, special, incidental or consequential damages resulting from or arising out of or in connection with using this product, whether or not ZTE had been advised, knew or should have known the possibility of such damages.

Your Phone

Phone Overview

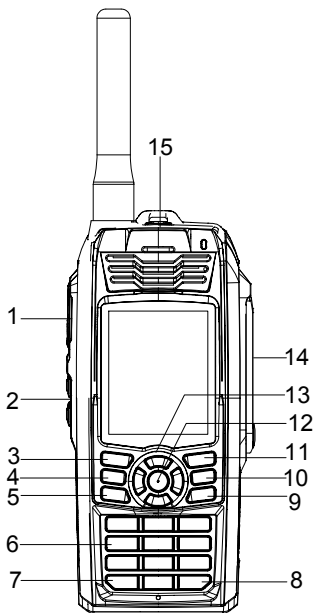

Keys and Functions

1	PTT Key Hold it to make a PTT call and release it to listen to others or back to idle status.
2	Volume Up / Down Key <ul style="list-style-type: none">● In standby mode, press to set the incoming call ring volume.● In standby mode, press and hold Volume Down Key to access the highest brightness mode.
3	Left Soft Key <ul style="list-style-type: none">● The current function of the key is shown on the bottom bar of the display.● In standby mode: Press the key to enter main menu in standby mode.
4	GPS Key Press to access to GPS menu.
5	Call Key <ul style="list-style-type: none">● Press to send or answer calls.● In standby mode: Press to show all calls.
6	Number Keys <ul style="list-style-type: none">● Press to enter numbers.● Press and hold the number key to start speed dial.

7	<p>* Key</p> <ul style="list-style-type: none"> ● Press to enter "*". ● In an editing screen: Press to input punctuation and symbols. ● Hold to lock the keypad in standby mode.
8	<p># Key</p> <ul style="list-style-type: none"> ● Press to enter "#". ● In an editing screen: Press to change the input method. ● In standby mode: Press and hold to activate/deactivate vibration mode.
9	<p>End Key</p> <ul style="list-style-type: none"> ● Press and hold to turn the phone on/off. ● Press to end a call.
10	<p>Music Key Press to open the Music Player.</p>
11	<p>Right Soft Key</p> <ul style="list-style-type: none"> ● The current function of the key is shown in the bottom line of the display. ● In standby mode: Press the key to enter Contacts.
12	<p>OK Key</p> <ul style="list-style-type: none"> ● In standby mode: Press to access to main menu. ● In list and menu: Start an application/function.
13	<p>Navigation Keys (Up/Down/Left/Right Key)</p> <ul style="list-style-type: none"> ● Used to move the highlight or cursor. ● In standby mode, press the Left / Right Key access to shortcut menu, please refer to Phone Settings for detail.

14	Earphone jack (To connect the earphone with the phone, please remove the cover first.)
15	Emergency Call Key Press it to make emergency call.

Getting Started

Installing Battery and (U)SIM Card

The charger and other accessories should be disconnected from your phone before you insert or remove the battery or UIM card.

Notes:

- The phone automatically switches off if the battery voltage is too low.
 - When not using the battery for a long period, remove it from the phone and store it in a cool dry place.
1. Press and hold **End Key** to turn off the phone.
 2. Remove the back cover.

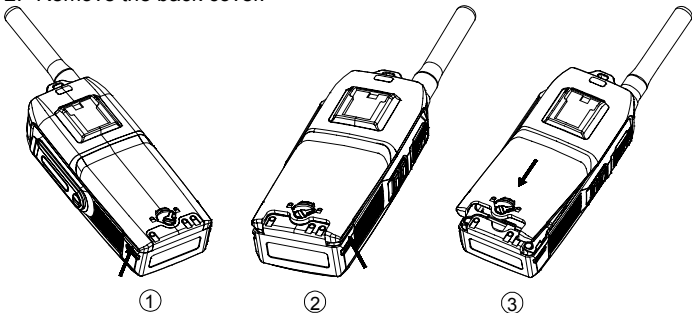

Notes:

When the battery is inside, put finger on the finger grip, and then lift up the battery to remove the battery.

3. Insert the UIM card into the card holder, with the metal contacts facing downward and the cut corner in the right direction. Make sure it is pushed all the way to the end as shown below.

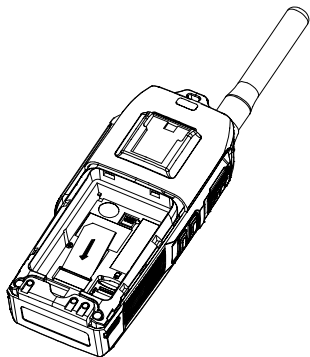

4. Insert the battery carefully with the contacts located against the metal springs.

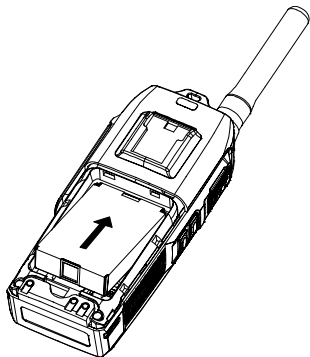

5. Push the battery until it clicks into position.
6. Place the cover onto the back of your phone.

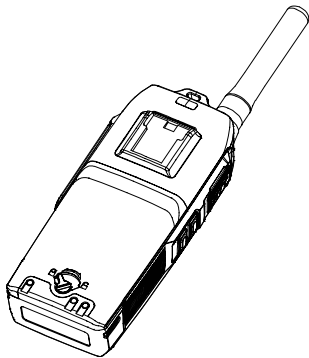

Caution:

Do not force the cover down by pressing on it. This will damage the cover.

Inserting Memory Card

The memory card gives your handset a very large memory capacity. This allows you to save multimedia data, including images, photos, MP3 audio files, and ring tones. You can also use this memory card to store any other files.

Tips:

Your phone can support a memory card with capacity up to 16 GB.

1. Open the memory card slot.

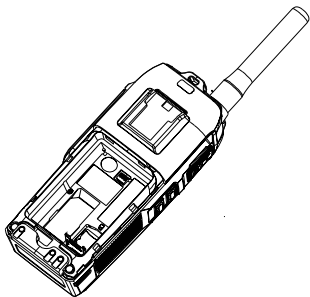

2. Firmly insert the memory card into the slot until it clicks into place.

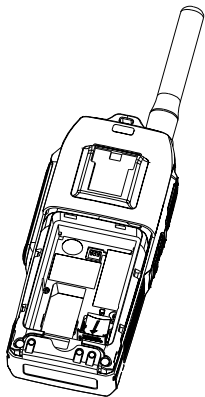

3. Close the memory card slot.

Caution:

Only use ZTE approved memory cards for this device. Any use of unapproved memory cards may cause loss of data or damage to your phone.

Charging Your Phone

Your phone is powered by a rechargeable battery. The battery is not fully charged when first unpacked, but there may be enough power to power your phone on. You should use it up completely before charging the battery for the first time. Charge the battery with the procedure indicated below.

1. Insert the battery and mobile phone into compartments of charger.

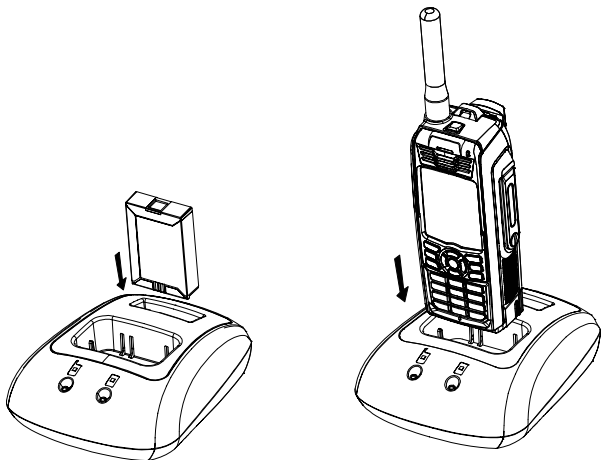

2. Connect the AC adapter and charger with mini 5 pin data cable.

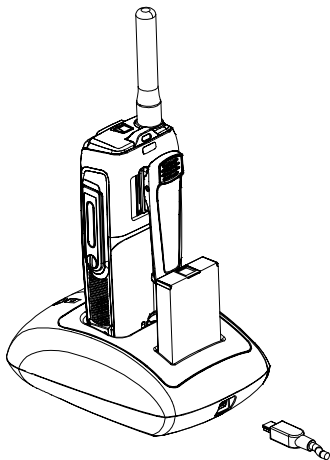

3. Plug in the AC adapter to an electrical outlet to start charging the battery and the phone.
When the light is red, it is charging; when it turn green, it is fully charged.
4. Remove the charger from the socket once charging is completed.

Notes:

- Make sure that the adapter is inserted into the correct position. Do not force the connector into the port.
- The battery will be fully charged for 3~4 hours.
- Use the charger provided by the original provider. Using unapproved charger may cause danger and violate the authorization and warranty rules of the phone.
- If the phone is over-used in shortage of battery or not used for a long time, the screen may not display the charge indicator until it is continuously charged for 10 to 40 minutes.
- For maximum battery performance, it is recommended that you

completely charge the battery before using the phone for the first time. A new battery's full performance is achieved only after three complete charge and discharge cycles.

- Once the charging is complete, remove the charger from both the power outlet and the phone.
- To charge the battery, you can use the provided charger or the USB data cable.
- Charging is only possible within a temperature range of -5 °C to +45 °C.

Security Settings

Handset Code

Phone password can protect your phone efficiently and avoid illegal usage. If phone password protection is activated, you should input the correct password at phone start-up.

- For a new bought phone, the protection function is not activated and the default password is 0000.
- In standby mode, select **Menu > Settings > Security Settings > Use Phone Code** to activate or deactivate password protection.
- In standby mode, select **Menu > Settings > Security Settings > Change Phone Code** to change phone password. It is suggested to change the password according to your requirement.

Notes:

Please remember the password you set, otherwise your handset can not be used normally, need to contact ZTE after-sales service center.

PIN Code

PIN code is the personal identification code of UIM card, used to avoid illegal usage for your UIM card. Once PIN code is started, the correct PIN code should be input at phone start-up, otherwise the phone can only execute emergency call.

- For a new bought card, the default code is supplied by the service

provider.

- In standby mode, select **Menu > Settings > Security Settings > Use PIN Code** to activate or deactivate PIN code.
- In standby mode, select **Menu > Settings > Security Settings > Change PIN Code** to change PIN code.

Notes:

If you change PIN code, please remember it clearly.

PUK Code

After inputting wrong PIN code continuously for three times, the phone will lock the UIM card and prompt you to input PUK code to unlock.

Notes:

PUK code is the specified unlock code for UIM card, when UIM card is locked, input the correct PUK code and then input the new set PIN code, UIM card can then be used normally.

- PUK code may be supplied with the new bought card, the detail can refer to the service provider.
- If PUK code is supplied with the new bought card, please keep it safely.
- PUK code can only be input continuously for 10 times. If you input wrong PUK code for 10 times, UIM card will be locked indefinitely.

Restoring Factory Settings

Restoring factory settings can recover all the items in **Settings** menu to the default values.

1. In standby mode, select **Left soft key [Menu] > Settings > Security Settings > Restore Factory Settings**.
2. Input the phone password, and then press **Left soft key [OK]**.
3. Press **Left soft key [Yes]** to restore factory settings.

Notes:

Restoring the phone does not influence PIN code.

Or press **Right soft key [No]** to cancel restore.

Clear User Data

Clearing user data can recover all the items in Data Folder to default values.

1. In standby mode, select **Left soft key [Menu] > Settings > Security Settings > Clear User Data**.
2. Input the phone password, and then press **Left soft key [OK]**.
3. Press **Left soft key [Yes]** to restore the default values.

Notes:

Restoring the phone does not influence PIN code.

Or press **Right soft key [No]** to cancel restore.

Basic

Switching On/Off

Notes:













Do not power on your phone if wireless phone use is unapproved, or when it may cause interference or danger.







1. Press and hold the **End Key** to turn on the phone.

Tips:

- When being asked, enter your PIN (Personal Identification Number) code or handset code and press the **OK Key** to confirm.
 - The PIN code is the password provided by your network service provider. You need this password to use the UIM card.
 - When the entered PIN code or handset code is accepted, the phone will automatically search for the designated network. After a few seconds, your phone will show the standby mode.
2. To power off the phone, press and hold the **End Key** from the standby mode.

Indicators and Icons

	Signal strength		Roam
	New short message		Message box full
	Vibrate		Vibrate + ring tone
	Alarm		Silent
	Calling		Earphone
	Battery capacity		T-flash card

	PTT group call		PTT private call
	Idle		Speak
	Listen		PTT speed dial
	Watching function activated	–	–

Keypad Lock

Use the keypad lock to prevent the keys from being accidentally pressed.

1. In standby mode, select **Left soft key [Menu] > Settings > Phone Settings > Auto Keypad Lock** and then select **On** to activate, or select **Off** to deactivate.
2. To unlock the keypad, press the **Right soft key [Unlock]** first and then press *** Key**.

Tips:

- When the keypad is locked, **Unlock** is displayed at lower right of the screen.
- If the call is coming when the keypad is locked, you can press the **Call Key** to answer. After ending or rejecting the call, the keypad will be locked automatically.
- When the keypad lock is on, calls may be possible to the official emergency number programmed into your device.

Making a Normal Voice Call

1. If required, press and hold the **0 Key** for the international prefix “+”.
2. Enter the number, and press the **Call key** to make a call.
3. Press the **End Key** to end the call.

Functions during Normal Voice Call

During the normal voice call, you can select the **Left soft key [Option] > Record On** to record the call. This operation need to insert T-card first.

PTT Calls

Make PTT Calls

1. You could make PTT calls by the following means.

- Dial Directly

Enter the desired PTT number in standby mode for private calls; if you want to make PTT group calls, press the **# Key** and then enter the desired group number in standby mode.

- Dial via Contacts

In standby mode, select **Left soft key [Menu] > Contacts**; and then select your desired contact or system group by pressing the **Up / Down Keys**.

- Dial via Call History

In standby mode, press the **Call Key** to access to **All Calls** interface; and then press the **Up / Down Keys** to select your desired contact or phone number.

- Dial via PTT Speed Group

In standby mode, press the **Up / Down Keys** to select your desired PTT speed group.

2. Hold the **PTT Key** to start dialing, and speak after hearing a beep sound;
3. Release the **PTT Key** to listen to the other party or back to the idle status.

Note: Only PTT private calls can be dialed via Call History.

Receive PTT Calls

When receiving PTT calls, you firstly hear a short beep sound, and then hear the other party speaks without any operation. After the party finishes speaking, hold the **PTT Key** and speak after hearing a beep sound.

Release the **PTT Key** to listen to the other party or back to the idle status.

End / Exit PTT Calls

- In private calls, press the **End Key** or select **End Call** to end a call.
- In group calls, press the **End Key** to exit from a group call.
- The group caller or leader can select **End Call** to end a group call.

Note: Contact your network service provider for detailed PTT call authorities.

Functions during PTT Calls

- Press the **Volume Up / Down Keys** to adjust the volume.
- Press the **OK Key** to activate or deactivate the speaker.
- Select the **Left soft key [Option] > Record On** to record the call.

Note: Recording the call need to insert T-card first.

PTT Watching Function

This function enables your phone receive the group calls which are set in the current watching list. Only 3 groups can be set as watching group at the same time.

Set PTT Watching Function

1. In standby mode, select **Left soft key [Menu] > PTT Settings > Watching Function**;
2. Select **On** or **Off** to activate or deactivate PTT watching function.

Set PTT Watching List

1. In standby mode, select **Left soft key [Menu] > Contacts > PTT System Group**;
2. Press the **Up / Down Keys** to select a group and then select **Watch** to add the group into the watching list.

Notes: The current speed dial group is as watching group by default.

Broadcast Call

Broadcast Call is an unilateral call. It broadcasts the call to the group members and the group members can receive the call but not allow answering the call.

Operation Method

1. Enter “ ## ”, in standby mode;
2. Enter the group number of the call;
3. Hold **PTT key** to start the broadcast call and talk after hearing a beep sound

PTT Emergency Calls

With the highest priority, emergency calls could be made through the **Emergency Call key**.

You can make the emergency call by the following ways:

- In standby mode, enter “# + group number” or a private PTT number, then hold **Emergency Call key** to send the call;
- Choose a call number from call history and hold the **Emergency Call key** to send;
- Choose a call number from contacts and hold the **Emergency Call key** to send;
- In standby mode, hold the **Emergency Call key** to send the emergency call which has been preset in the PTT Settings (Please refer to section “**PTT Settings**” for details).

Note: Please consult the network operator for the PTT emergency call authority.

Text Input

Your phone offers text input modes: Multitap mode (**abc/Abc/ABC**), Numbers mode (**123**), eHiText mode (**eng**). Text mode includes uppercase and lowercase modes.

When you are in a field that allows characters to be entered, you will notice the text input mode indicator in the upper right corner of the display.

You can key in letters, digits, characters and symbols when writing text or editing contact record information, following the common instruction in the table hereinafter.

Operation	Method
Input Letters	Multitap mode —“ abc/Abc/ABC ”, press corresponding letter key till the letter appears.
Input Words	eHiText mode — “ eng ”, press any key once to key in any word.
Input Digits	Numbers mode — “ 123 ”, press digit key once.
Input Symbols	Symbols mode — Press the * key to enter the symbols mode and press corresponding digit key. Or press 1 key till the symbol (common symbols) appears except for numbers mode.
Input Space	Press 0 key , except for being in numbers mode.
Erase Character	Press the Right soft key .
Move cursor	Press the Navigation keys .
Change input mode	Press the # key to select another text mode.

Contacts

Adding Contact

You can store contacts with a variety of phone and fax numbers.

The phone can store up to 1000 items. The capacity of a phone book in your UIM card depends on the type of UIM card provided by your service provider. The saved location can be identified by the icon before the contacts.

1. Select **Left soft key [Menu] > Contacts > Add Name**.
2. Select save location.
3. Enter the information of contact.
4. Press **Left soft key [Save]** to save the new contact.

PTT System Group

Note: PTT system group is updated by system automatically.

1. In standby mode, select **Left soft key [Menu] > Contacts > PTT System Group**;
2. Select your desired system group by pressing the **Up / Down Keys**;
3. Hold the **PTT Key** to start dialing, and speak after hearing a beep sound; Release the **PTT Key** to listen to the other party or back to the idle status.

Searching Contact

1. Select **Left soft key [Menu] > Contacts > All List**.
2. Input the name you want to find.
3. Press the **Up key** or **Down key** to scroll though the corresponding name(s) and record(s) in the list. Scroll to the name you want, and press the **OK key** to view the details.

Notes:

All the Names will be list by the letter of the name. If no contact could be found or not exist in the list, "**No Items**" will be displayed.

Adding group

Assign group for the contacts saved in phone.

1. Select **Left soft key [Menu] > Contacts > All List**.
2. Select the desired contact.
3. Select **Left soft key [Option] > Edit**.
4. Press the **Up key** or **Down key** to select Groups.
5. Press the **Left key** or **Right key** to select desired group.
6. Press the **Left soft key [Save]** to save the settings.

Setting Speed Dial

1. Select **Left soft key [Menu] > Contacts > All List**.
2. Select the contact, press the **OK key** to view details.
3. Scroll to the number and choose **Set Speed Dial Number** in Option.
4. Select a Not Set slot in list and press the **OK/Left soft key**.
5. Press the **Right soft key** to return to previous menu.

Viewing Speed Dial

1. Select **Left soft key [Menu] > Contacts > Speed Dials**.
2. View contact record in **Speed Dial List**.

Making a Speed Dial

Hold the Speed Dial Number digit key to make a speed dial in the standby mode.

Other Options

1. Select **Left soft key [Menu] > Contacts > All List**.
2. Press the **Left soft key [Option]** to enter the submenu list, and you

can do following operations:

Options	Function
Add Name	Add new contact.
Edit	Edit the contact information.
Send Message	Send message to the contact's default number.
Call	Dial the contact's default number.
Multiple Select	Select multiple contacts.
Delete	Delete current selected contact.
Delete All	Delete all contacts.
Send Name Card	Send information of this contact via SMS.
Copy to Phone	Copy contact in UIM card to the phone.
Copy to UIM	Copy contact on the phone to UIM card.
Move to Phone	Move contact in UIM card to the phone.
Move to UIM	Move contact on the phone to UIM card.

Message

SMS (Short Messaging Service) allow you to send text messages and manage the messages that you sent and received.

Sending SMS

1. Select **Left soft key [Menu] > Messages > New Message.**
2. Enter the recipient(s) party's number. (Or **select Left soft key [Option] > Contacts** to choose the recipient(s).)
3. Press the **Down key** to the text field.
4. Edit the message.
5. Press the **OK key** to send your message.

Message Settings

1. Select **Left soft key [Menu] > Messages > Message Settings.**
2. Select **General Settings** to make auto delete, auto save, signature settings.
3. Select **SMS Settings** to make SMS settings, such as delivery, priority, validity, save location, call back settings, etc.

Call History

In standby mode, select **Left soft key [Menu] > Call History** to check the call logs and call duration.

Multimedia

Music Player

When you have some audio files stored in your phone, you can create a playlist to play your audio files in the preferred order.

Setting Music Play Mode

1. In standby mode, press **Left soft key [Menu]** to enter main menu.
2. Select **Multimedia > Music Player > Option > Play Mode** to set play mode as **Random**, **Order** or **Single**.

Managing Play List

1. Select **Left soft key [Menu] > Multimedia > Music Player > Option > Current List > Option > Add**.
2. Select an audio file folder in phone or memory card.
3. Press the **OK key** to mark the audio files, press the **Left soft key [OK]** to save the audio files to the playlist.
4. Select Save List, input the list name.
5. Press the **Left soft key [OK]** to add new play list.

Playing a Music

You can use the following methods to play a sound file.

- Open **File Manager** to play a sound file.
 1. In standby mode, select **Left soft key [Menu] > File Manager > Music**.
 2. Select your desired audio file, press the **OK key** to play an audio file.
- Select **Menu > Multimedia > Music Player** to play a sound file.
 1. In standby mode, select **Left soft key [Menu] > Multimedia > Music Player** to activate media player.
 2. Select **Left soft key [Option] > Current List**.
 3. Press the **Up key** and **Down key** to select the audio file you would like to play.

4. Press the **OK key** to play.
- Select **Menu > Multimedia > Voice Recorder** to play a sound file.
For details, please refer to chapter: *Voice Recorder > Playing a sound file*.

Voice Recorder

This function allows you to record a voice memo, and you can also set the voice memo as ringtone.

Recording

1. Select **Left soft key [Menu] > Multimedia > Voice Recorder**.
2. Press the **OK key** to start recording your voice memo.
3. Press the **Left soft key/OK key [Pause]** to pause, press the **Left soft key/OK key [Continue]** to resume recording, and press the **Right soft key [Stop]** to stop recording and save the memo into Record List directory automatically.
4. Select **Option** to check memo or make settings, etc.

Playing a sound file

1. Select **Left soft key [Menu] > Multimedia > Voice Recorder**.
2. Press the **Left soft key [Option]**, and then select **Record List**.
3. Press the **Up / Down keys** to select the memo you would like to play.
4. Press the **OK key** to play the sound file.

EBook

You can read Ebooks in **File Manager**.

Notes:

You can copy texts to memory card as Ebooks.

File Manager

File Manager is a storage area for photos, audios, etc.

In standby mode, select **Left soft key [Menu] > File Manager** to enter the file manager.

Access the memory card, do as follows:

1. Select **Left soft key [Menu] > File Manager** to open file manager.
2. Select **Memory Card** to view the files on memory card. By pressing the **Left soft key [Option]**, you can create new folder, or delete the file.

Other Facilities

Alarm

You can set the alarm to ring if required.

1. In standby mode, select **Left soft key [Menu] > Magic Box > Alarm**.
2. Select **No Set** to add a new alarm, and press the **Left soft key [Save]** to save it.
3. Select **Option > Edit** to view the alarm settings.
4. Select **Option > Snooze Setting** to set the alarm duration.
5. Select **Option > Disable All Alarms** to disable all alarms.

Notes:

If you turn the alarm on, the icon will be displayed in standby mode.

Calendar

You can conveniently access and modify your agenda:

1. In standby mode, select **Left soft key [Menu] > Magic Box > Calendar** to enter Calendar interface.
2. Press the **Navigation keys** to move to different date.
3. Select **Left soft key [Options] > New Task** to add Subject, Start Time, End Time, Remind, or Remind Interval. Press the **Left soft key** to save.
4. Press the **Left soft key [Options]** to display more options.
 - **View By day**: View the schedule lists of the current day.
 - **View All Tasks**: View all schedule lists.
 - **Go To Today**: Go to the calendar window indicating today.
 - **Go To Date**: Input the date, your phone go to the calendar window indicating the date you input.
 - **Delete Before Date**: Input the date, your phone deletes all the schedule lists earlier than the date.
 - **Delete All Tasks**: Delete all schedule lists.

Reader

Your mobile phone supports TXT files. Select **Left soft key [Menu] > Magic Box > Reader** to read the e-books saved in T-flash card. Select **Option** and you can view the recently-read books and labels.

Stopwatch

You can measure time and take split times or lap times, for example, in different sports.

1. In standby mode, select **Left soft key [Menu] > Magic Box > Stopwatch**.
2. Select **Normal timing**, **Lap timing** or **Split timing**, and then press the **Left soft key [Start]** to start timing.
3. Press the **Left soft key [Split/Lap]** to complete a period of time/lap.
4. Press the **Right soft key [Pause]** to pause.
5. Press the **Left soft key [Continue]** to continue timing.
6. Press the **Right soft key [Reset]** to reset.

Calculator

The phone provides simple calculating functions, such as addition, subtraction, multiplication and division.

1. In standby mode, select **Left soft key [Menu] > Magic Box > Calculator**.
2. Press key "0~9" to enter numbers.
3. Press the* **key** to enter the decimal point.
4. Press the **Up key**, **Down key**, **Left key**, or **Right key** to choose +, -, ×, /.
5. Press the **Right soft key [Delete]** to clear the last digit you input.
6. Press the **OK key** to view the result.

Unit Converter

1. In standby mode, select **Left soft key [Menu] > Magic Box > Unit Converter**.
2. Choose any unit to convert.
3. Press the **Up key** or **Down key** to switch between original unit 'from' and equals unit 'to'. Press the **Left key** or **Right key** to select the original unit which is "from" and equals "to".
4. Enter numbers with the original unit to get the corresponding result.

Notepad

1. In standby mode, select **Left soft key [Menu] > Magic Box > Notepad** to enter Notepad interface.
2. Press the **Left soft key [Option]** to edit, select record, delete or create new note.

JAVA

Your handset supports JAVA application.

Settings

Profile

Your handset supplies several predefined user profiles, and you can choose a certain profile according to your surroundings.

You can also edit the appropriate profile depending on the current condition.

Display Settings

In standby mode, select **Left soft key [Menu] > Settings > Display Settings**:

- Select **Screen Settings**
 - Select **Wallpaper Settings**, use the picture saved in **Phone** or **Memory card** as wallpaper, displayed in standby mode.
 - Select **Backlight Time** to set backlight duration.
 - Select **Brightness** to adjust the screen brightness.
 - Select **Idle Display Content** to set idle mode.
- Select **Theme Settings** to select theme style.
- Select **Banner** to input the idle greet words.
- Select **Roaming Reminder** to activate or deactivate reminder for roaming network.
- Select **Keypad Light Settings** to set keypad light mode.

Phone Settings

1. In standby mode, select **Left soft key [Menu] > Settings > Phone Settings**.
2. Select **options**.
 - Select **Language** to set the language available.
 - Select **Shortcut** to set the **Left/Right key** shortcut functions.
 - Select **Accessory Device** to select the device connected with the

phone.

- Select **Auto Keypad Lock** to activate or deactivate the auto keypad lock, set the waiting time and whether to lock the PTT key when the keypad is locked.
- Select **Power Save** to activate or deactivate power-saving mode.
- Select **Auto Power On/Off** to set the time of powering on/off the handset automatically.
- Select **Version Info.** to view the preset PRL (Preferred Roaming List) version, software and hardware version of the phone.

Call Settings

1. In standby mode, select **Left soft key [Menu] > Settings > Call Settings.**
2. Select your desired item to make setting:
 - **Call Settings:** set whether to activate call forwarding, call waiting and connection reminder.
 - **Call Forwarding:** this function enables you to forward your incoming calls to an appointed phone number. Contact your network service provider to activate the function. There are 4 kinds of call forwarding: Default, All, Busy and No Answer. You can activate or deactivate one kind of call forwarding and set the forward number.
 - **Call Waiting:** .If you activate the function, there will be an alert to inform you of a new incoming call when you are making a call. You can receive the second call while keep the first call connected. Contact your network service provider for details.
 - **Connection Reminder:** set whether to activate or deactivate the connection reminder function.
 - **Answer Settings:** set whether to activate or deactivate **Any Key Answer** or **Headset Auto Answer.**
 - **Call Information Reminder:** set whether to activate or deactivate minute reminder or missed calls reminder.
 - **IP Dial:** set IP number, and select **Option** to edit, delete IP number, or set the IP number as default.

- **Black List:** view the black list, or select **Option** to add numbers, contacts or recent contacts to black list; delete numbers in black list.
- **Voice Privacy:** set whether to activate or deactivate the voice privacy function.
- **International Dial:** set the international dial mode as **Automatic** or **Manual**.

Notes:

The functions need network support. For details, please contact your service provider.

Connect Settings

1. In standby mode, select **Left soft key [Menu] > Settings > Connect Settings**.
2. Select **USB Disk Mode** to set the memory card of the phone as a disk.
3. Select **JAVA** to view access point and select proxy server.

Time and Date Settings

In standby mode, select **Left soft key [Menu] > Settings > Time & Date Settings**.

- Select **Time Format** to select display format of time in standby mode.
- Select **Date Format** to select display mode of date in standby mode.

PTT Settings

1. In standby mode, select **Left soft key [Menu] > PTT Settings**;
2. Select your desired item to make setting:
 - **PTT Function**: select **On** or **Off** to activate or deactivate PTT function.
 - **Watching Function**: select **On** or **Off** to activate or deactivate PTT watching function.
 - **Emergency Call**: set the emergency call type and the number. The type can set as **Normal Call**, **Private Call**, **Group Call** and **DAS**.
 - **SupplementSvc**: set the PTT supplement service.
 - **Call Attribute**: set PTT call attribute as **Normal** or **Pre-emptive**.
 - **DynaManagement**: manage the PTT group.
 - **Add Member**: add member to PTT group.
 - **Delete Member**: delete member from PTT group.
 - **Set Priority**: set group member PTT call priority.
 - **Set Talk Time**: set group member maximum talk time.
 - **Supplement Svc Set**: set the supplement functions.
 - **Private Call Forward**: activate, deactivate or query PTT private call forward function, and set call forward number.
 - **Duty Number**: set duty number and status. when the status set as **onduty**, you can receive the duty number PTT call, when the status set as **offduty**, you would not receive the duty number PTT call.
 - **PTT CNIR**: set PTT number identification restriction function. After activate this function, PTT number will not be identified during the PTT call.
 - **Call Alert Busy**: activate, deactivate or query call alert busy function. After activate this function, You could receive the other incoming call prompt when you are making the call.
 - **Key Set**: set the key function.
 - **End Key During PTT Call**: set the function of End Key during the

PTT call.

- **Auto Keypad Lock:** activate or deactivate the auto keypad lock, set the waiting time and whether to lock the PTT key when the keypad is locked.
- **Standby and performance Setting:** set the standby mode and performance of the phone.
- **Accessory Device:** select the accessory device connected with the phone during the PTT call.

GPS

The mobile phone supports GPS. GPS can provide locating function.

1. In standby mode, select **Left soft key [Menu] > GPS**.
2. Select **GPS Setting**, and then select **On** to activate GPS function.
3. Select **GPS Information** to start locating.
After locating successfully, the current location information will display on the screen.
4. Select **Message Center Num** to set the message center number.
The message center number is used to receive the location information automatically, it is provided by the network operator.
5. Select **Format Setting** to set the information display mode.

Note: Please consult the service provider for the **message center number**.

Troubleshooting and FAQs

If your phone appears following phenomenon in the process of application, please read following relative information at first. If the problems still cannot be solved, please contact with the distributor or service provider.

Problem	Possible Cause	Solution
Weak signal	The area covered with weak signal, such as basement, and the area near high-rise buildings.	Move to the area covered with strong signal.
	The network is busy. For example, you may fail to make calls during rush hours because of busy network.	Avoid using mobile phone during rush hours.
	You are too far away from station.	Contact your network service provider for station location.
Echo or noise	Poor network trunk.	Press the End Key and dial again.
	Poor telephone line.	Press the End Key and dial again.
Fail to use some functions	Your network service provider does not support such functions, or you have not applied to activate the functions.	Contact your network service provider.
Charging failure	The battery or charger is damaged.	Contact your local dealer.
	The temperature is lower than 0 °C or higher than 45 °C.	Avoid charging battery at too low or high temperature.

Problem	Possible Cause	Solution
	The battery is not connected well with charger.	Connect again, and make sure the cables are connected correctly.
Short standby time	Standby time depends on the setting by network service provider, and varies from provider to provider.	Power off the mobile phone.
	Battery power is run out.	Replace the battery.
	Network connection failure	Move to the area with network, or power off the mobile phone.
Powering on failure	The battery power is run out.	Charge the battery.
UIM card failure	UIM card is failed or damaged.	Return the UIM card to network service provider to test.
	UIM card is not inserted correctly.	Insert the UIM card correctly.
	The metal contacts of UIM card are dirty.	Clean the metal contacts with soft and dry cloth.
Network connection failure	Invalid UIM card	Contact your network service provider.
	Out of network service area	Contact your network service provider for network service area.
	Weak signal	Move to an open area; if you are in a room, move to the area near windows.
PIN code is locked.	Input incorrect PIN code three times consecutively.	Input PUK code to unlock the PIN code, or contact your network service provider.

Problem	Possible Cause	Solution
Fail to add contact information	The contact memory capacity is all used.	Delete unnecessary contact information.

Technical Parameters

Phone specifications are shown in the following table.

Dimensions (H×W×D)	132 mm × 54 mm × 34 mm
Weight	About 248 g (with battery)
Display	176 * 220 pixels, 262 K TFT Color, 2.0 inch
Extended memory	16 G memory card
Battery	1700 mAh Lithium ion (Li-ion)
Performance	GIF/JPEG/BMP image; MP3/AMR/MIDI audio; Voice Recorder; PTT; GPS
Continuous idle time	About 200 hours
Continuous talk time	About 360 minutes
Charge time	Approximately 3 hours

Declaration of RoHS Compliance

To minimize the environmental impacts and take more responsibilities to the earth we live on, this document shall serve as a formal declaration that the ZTE-J G500 manufactured by ZTE CORPORATION is in compliance with the Directive 2002/95/EC of the European Parliament - RoHS (Restriction of Hazardous Substances) with respect to the following substances:

1. Lead (Pb)
2. Mercury (Hg)
3. Cadmium (Cd)
4. Hexavalent Chromium (Cr (VI))
5. Polybrominated biphenyls (PBBs)
6. Polybrominated diphenyl ethers (PBDEs)

Disposal of Your Old Appliance



1. When this crossed-out wheeled bin symbol is attached to a product, it means the product is covered by the European Directive 2002/96/EC.
2. All electrical and electronic products should be disposed of separately from the municipal waste stream via designated collection facilities appointed by the government or the local authorities.
3. The correct disposal of your old appliance will help prevent potential negative consequences for the environment and human health.

For this product's recycling information based on WEEE directive, please send an e-mail to weee@zte.com.cn

EC DECLARATION OF CONFORMITY

C E0700

It is hereby declared that following designated product:

Product Type: GoTa Digital Trunking Phone

Model No: ZTE-J G500

Complies with the essential protection requirements of the Radio and Telecommunication Terminal Equipment Directive (EC Directive 1999/05/EC) and the Electromagnetic Compatibility Directive(2004/108/EC).

This declaration applies to all specimens manufactured identical to the samples submitted for testing/evaluation.

Assessment of compliance of the product with the requirements relating to the Radio and Telecommunication Terminal Equipment Directive (EC Directive 1999/05/EC) was performed by American TCB (Notified Body No.1588), based on the following standards:

Safety	EN60950-1:2006+A11:2009
EMC	EN 301 489-1 V1.8.1/-3 V1.4.1/-25 V2.3.2
Radio	EN 300 440-1 V1.6.1/-2 V1.4.1 EN 301 526 V1.1.1
Health	EN 50360:2001/EN 62209-1:2006/ EN62311: 2008/ IEC 62209-2:2010

This declaration is the responsibility of the manufacturer:

ZTE Corporation

ZTE Plaza, Keji Road South, Hi-Tech, Industrial Park,
Nanshan District, Shenzhen, Guangdong, 518057, P.R.China

Authorised person signing for the company:

Xu Feng Quality Director Of ZTE Corporation

Name in block letters & position in the company

Shenzhen, 13th August 2011

Place & date



Legally valid signature